

FRANC

TRAILERS **TRIGANO**

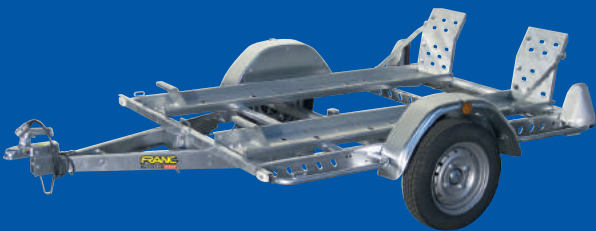

NOTES



A series of horizontal lines for taking notes, starting from the top of the page and extending to the bottom.

LEISURE RANGE



SIMPLE AND ROBUST, THE LEISURE TRAILERS RANGE ARE SPECIALLY DESIGNED FOR LEISURE AND DIY

- ⦿ Designed for robustness in galvanised steel
- ⦿ Tipping facility (except RC 110)
- ⦿ Protected 6 function lights in the lighting board
- ⦿ Steel floor
- ⦿ Straight drawbar
- ⦿ Removeable rear panel
- ⦿ Polyester mudguards (except GA150)
- ⦿ Rubber torsion suspension

TRIGANO trailers are delivered with a Certificate of Conformity (COC) and comply with the European Directive 2007/46/CE approved by the European Parliament and council



TRAILERS	1 RC 110	2 GA 130	3 GA 150
Gross weight	300 kg	450 kg	500 kg
Maximum payload	240 kg	385 kg	407 kg
Unladen weight	60 kg	65 kg	93 kg
Axle capacity	300 kg	450 kg	600 kg
Drawbar	Staight	Staight	Staight
Overall dimensions (cm)	175 x 120 x 86	197 x 120 x 88	228 x 135 x 89
External box dimensions (cm)	110 x 92 x 38,5	128 x 92 x 38,5	156 x 100 x 38,5
Internal box dimensions (cm)	105 x 87 x 32	123 x 87 x 32	151 x 95 x 32
Box volume (litres)	292	342	459
Tipping box		⦿	⦿
Protected light	6 function	6 function	6 function
Wheels	350 x 8	480 x 8	500 x 10
Mudguards	Plastic	Plastic	Steel
Hinged and removable panel	Rear	Rear	Rear
Trailer cover hook	Dark plastic	Dark plastic	Dark plastic

OPTIONAL ACCESSORIES	1 RC 110	2 GA 130	3 GA 150
Spare wheel	⦿	⦿	⦿
Spare wheel holder	⦿	⦿	⦿
Coupling lock	⦿	⦿	⦿
Flat cover	⦿	⦿	⦿
ABS lid		⦿	⦿
Universal load bar kit	⦿	⦿	⦿
Rack for ABS lid		⦿	⦿
Steel high sides		⦿	⦿
Side rails		⦿	⦿
Ladder rack		⦿	⦿
Shock absorber kit		⦿	⦿
Prop stand	⦿	⦿	⦿
Jockey wheel + clamps	⦿	⦿	⦿
High cover x30cm	⦿	⦿	⦿

NLC RANGE



THE NLC RANGE SUITS PERFECTLY YOUR REGULAR DAY TO DAY NEEDS

- Galvanised steel construction
- Steel floor
- V drawbar
- Hinged and removable rear panel
- Rubber torsion suspension

TRIGANO trailers are delivered with a Certificate of Conformity (COC) and comply with the European Directive 2007/46/CE approved by the European Parliament and council



1
NLC 1510

2
NLC 2012

TRAILERS	1 NLC 1510	2 NLC 2012 SF	OPTIONAL ACCESSORIES	1 NLC 1510	2 NLC 2012 SF
Gross weight	500 kg	750 kg	Spare wheel	●	●
Maximum payload	386 kg	601 kg	Spare wheel holder	●	●
Unladen weight	114 kg	149 kg	Coupling lock	●	●
Axle capacity	600 kg	750 kg	Jockey wheel with clamp	●	●
Drawbar	V-drawbar	V-drawbar	Flat cover	●	●
Overall dimensions (cm)	249 x 141 x 86	296 x 160 x 90	High cover kit H 30 cm	●	
External box dimensions (cm)	150 x 105 x 35	200 x 120 x 35	High cover kit H 40 cm		●
Internal box dimensions (cm)	144 x 99 x 35	194 x 114 x 35	High cover kit H 80 cm		●
Box volume (litres)	499	774	ABS lid	●	●
Protected light	6 function	6 function	Rack for ABS lid	●	●
Wheels	155/70 x 13	155/70 x 13	Universal load bars	●	●
Mudguards	Plastic	Plastic	Steel high side kit H 40 cm	●	●
Hinged and removable panel	Rear	Rear	Mesh high sides H 40 cm	●	●
Vertical storage	●	●	Ladder rack	●	●
Tipping box		●			
Trailer cover hook	Dark plastic	Dark plastic			

NLC RANGE



THE VA 254 DE SF IS GOOD FOR GENERAL PURPOSE, THE DROPPING SIDES AND REAR PANEL ALLOWED YOU TO LOAD AND UNLOAD QUICKLY AND EASILY

- ⦿ Galvanised steel construction
- ⦿ Steel floor
- ⦿ V drawbar
- ⦿ Hinged and removable rear panel
- ⦿ Rubber torsion suspension

TRIGANO trailers are delivered with a Certificate of Conformity (COC) and comply with the European Directive 2007/46/CE approved by the European Parliament and council



TRAILERS	VA 254 DE SF
Gross weight	750 kg
Maximum payload	506 kg
Unladen weight	244 kg
Axle capacity	2 x 500 kg
Drawbar	Shaped V-drawbar
Overall dimensions (cm)	357 x 150 x 98
External box dimensions (cm)	257 x 142 x 43
Internal box dimensions (cm)	224 x 136 x 34
Box volume (litres)	1160
Protected light	6 function
Wheels	500 x 10
Hinged and removable panel	Sides and rear
Vertical storage	⦿
Trailer cover hook	Dark plastic
Jockey wheel included	Ø 48

OPTIONAL ACCESSORIES	VA 254 DE SF
Spare wheel	⦿
Spare wheel holder	⦿
Flat cover	⦿
Coupling lock	⦿
Anti theft wheel lock	⦿
Steel high side kit H 40 cm	⦿
Mesh high side H 40 cm	⦿

NFB RANGE



SAFETY, COMFORT THE NFB RANGE IS VERY RELIABLE, STRONG AND VERSATILE

- Hot galvanised welded chassis
- Anti-slip plywood floor
- V drawbar
- Hinged and removable front and rear panels
- Galvanised steel panels and mudguards
- Lashing points
- Tipping box on the single axle
- Protected 6 function light
- Jockey wheel included

TRIGANO trailers are delivered with a Certificate of Conformity (COC) and comply with the European Directive 2007/46/CE approved by the European Parliament and council

1 ▶
NFB 170 SF



◀ 2
NFB 200 SF



TRAILERS	1	2	3	4	5
	NFB 170 SF	NFB 200 SF	NFB 250 SF	NFB 254 SF	NFB 250 F130
Gross weight	750 kg	750 kg	750 kg	750 kg	1300 kg
Maximum payload	603 kg	583 kg	564 kg	515 kg	1047 kg
Unladen weight	147 kg	167 kg	186 kg	235 kg	253 kg
Axle capacity	750 kg	750 kg	750 kg	2 x 750 kg	1300 kg
Braked axle					●
Drawbar	V-drawbar	Shaped V-drawbar	Shaped V-drawbar	Shaped V-drawbar	Shaped V-drawbar
Overall dimensions (cm)	264 x 164	296 x 174	359 x 174	359 x 174	372 x 176
External box dimensions (cm)	170 x 124 x 40	200 x 134 x 40	256 x 134 x 40	256 x 134 x 40	256 x 134 x 40
Internal box dimensions (cm)	164 x 118 x 39	194 x 128 x 39	250 x 128 x 39	250 x 128 x 39	250 x 128 x 39
Box volume (litres)	754	968	1248	1248	1248
Tipping box	Yes	Yes	Yes	No	Yes
Plywood floor	12 mm	12 mm	12 mm	12 mm	12 mm
Protected light	6 function	6 function	6 function	6 function	6 function
Wheels	155/70 R13	155/70 R13	155/70 R13	155/70 R13	165 R13C
Mudguards	Steel	Steel	Steel	Steel	Steel
Hinged and removable panel	front and rear	front and rear	front and rear	front and rear	front and rear
Adjustable tipping bracket	●	●	●	●	●
Trailer cover hook	Dark plastic	Dark plastic	Dark plastic	Dark plastic	Dark plastic
Strapping point	●	●	●	●	●
Jockey wheel included	●	●	●	●	●

NFB RANGE



SAFETY AND COMFORT

- Hot galvanised welded chassis
- Anti-slip plywood floor
- V drawbar
- Hinged and removable front and rear panels
- Galvanised steel panels and mudguards
- Lashing points
- Tipping box on the single axle
- Protected 6 function light
- Jockey wheel included

TRIGANO trailers are delivered with a Certificate of Conformity (COC) and comply with the European Directive 2007/46/CE approved by the European Parliament and council

3 ▶
NFB 250 SF



4 ▶
NFB 254 SF



◀ 5
NFB 250 F130



OPTIONAL ACCESSORIES	1	2	3	4	5
	NFB 170 SF	NFB 200 SF	NFB 250 SF	NFB 254 SF	NFB 250 F130
Spare wheel	○	○	○	○	○
Spare wheel holder	○	○	○	○	○
Side spare wheel holder	○	○	○	○	○
Coupling lock	○	○	○	○	○
Flat cover	○	○	○	○	○
High cover kit 30 cm	○	○	○	○	○
High cover kit 80 cm	○	○	○	○	○
ABS lid		○			
Rack for ABS lid		○			
Steel high side kit H 40 cm	○	○	○	○	○
Mesh high side kit H 52 cm	○	○	○	○	○
Side rail	○	○	○	○	○
Ladder rack	○	○	○	○	○
Universal load bars	○	○	○	○	○

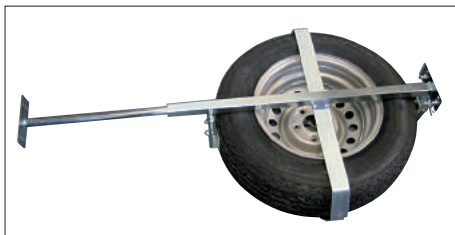

Spare wheel + Spare wheel holder

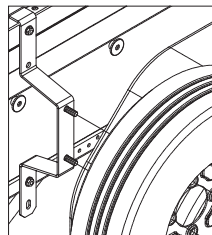

Spare wheel holder



Coupling lock



Flat cover



Raised cover



Dome cover



ABS lid



Hoop for ABS lid



Steel high side kit



Mesh high side kit H 50



Universal load bar

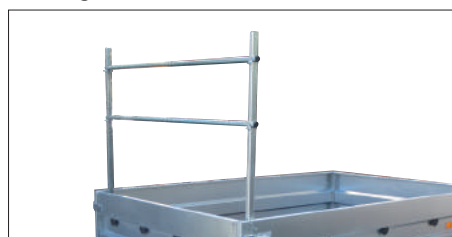

Ladder rack

MOTORCYCLE TRAILERS



MONO PRO

- Galvanised steel construction
- Delivered with rail and front wheel holder
- Loading motorcycle by tilting the chassis
- Loading ramp available as an extra

DUO PM

- Galvanised steel construction
- Delivered with 2 rails and front wheel holders
- Loading motorcycle by tilting the chassis
- Loading ramp available as an extra

TRIGANO trailers are delivered with a Certificate of Conformity (COC) and comply with the European Directive 2007/46/CE approved by the European Parliament and council

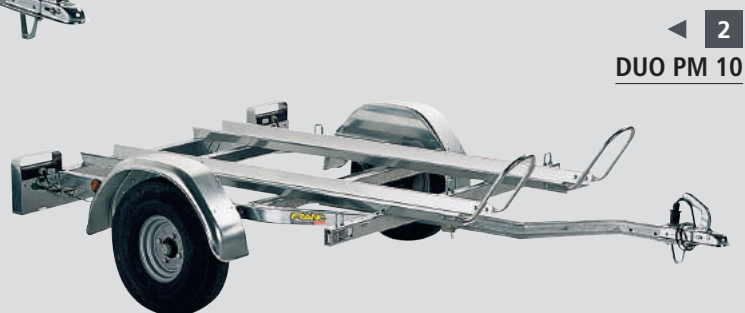

TRAILERS	1 MONO PRO 10	2 DUO PM 10	OPTIONAL ACCESSORIES	1 MONO PRO 10	2 DUO PM 10
Gross weight	350 kg	500 kg	Spare wheel	○	○
Maximum payload	270 kg	392 kg	Spare wheel holder	○	○
Unladen weight	95 kg	108 kg	Loading ramp x1	○	○
Axle capacity	500 kg	600 kg	Quad rails (set of 2)		○
Drawbar	Bend drawbar	Bend drawbar	Jockey wheel with clamp	○	○
Overall dimensions (cm)	290 x 148 x 77	290 x 172 x 77	Prop stand	○	○
Internal platform dimensions (cm)	164 x 100	164 x 130	Jerrycan holder	○	○
Rail included	1	2	Coupling lock	○	○
Tipping chassis	○	○	Shock absorber	○	○
Protected light	6 function	6 function			
Wheels	500 x 10	500 x 10			
Mudguards	Steel	Steel			
Vertical storage	○	○			
Lashing point	○	○			

MULTY TRAILER



PERFECT FOR ALL TYPE OF DUTY, VERSATILE, THE MULTY CAN SATISFY ALL YOUR NEEDS

- Hot galvanised welded chassis
- Tipping platform
- V drawbar
- Highly versatile
- Lashing points and multiple tie-down possibilities

TRIGANO trailers are delivered with a Certificate of Conformity (COC) and comply with the European Directive 2007/46/CE approved by the European Parliament and council



OPTIONAL ACCESSORIES

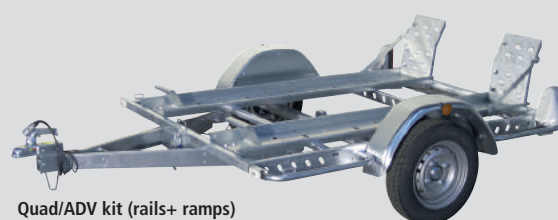

Quad/ADV kit (rails+ ramps)

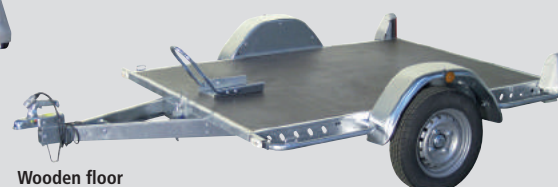

Wooden floor



Steel side kit

TRAILERS

	CHASSIS UNIVERSEL SF (MULTY)
Gross weight	750 kg
Maximum payload	647 kg
Unladen weight	103 kg
Axle capacity	750 kg
Drawbar	V-drawbar
Overall dimensions (cm)	300 x 192 x 65
Internal platform dimensions (cm)	200 x 145
Rail included	●
Tipping chassis	●
Protected light	6 function
Wheels	155/70 R13
Mudguards	Steel
Vertical storage	●
Adjustable tipping bracket	●
Lashing point	●

OPTIONAL ACCESSORIES

	CHASSIS UNIVERSEL SF (MULTY)
Spare wheel	●
Rail x1	●
Loading ramp x1	●
Quad loading ramp (set of 2)	●
Quad rails (set of 2)	●
Jockey wheel with clamp	●
Motorcycle wheel chock	●
Steel high side kit	●
Wooden floor	●

UTILITY RANGE



A LIGHT AND COMPACT CAR TRANSPORTER TO TOW YOUR SMALL VEHICLE. GREAT BEHIND A MOTORHOME

- Hot dip Galvanised welded chassis
- Protected multi-functional tail lights
- Rubber torsion suspension
- Strong v-drawbar
- Tipping bed
- 4 lashing points
- Mini ramps fixed

TRIGANO trailers are delivered with a Certificate of Conformity (COC) and comply with the European Directive 2007/46/CE approved by the European Parliament and council

1 ▶
PV 360 F130



mini ramps for easy access

Winch and winch carrier not included



◀ **2**
PV 360 F160

TRAILERS	1	2	OPTIONAL ACCESSORIES	1	2
	PV 360 F130	PV 360 F160		PV 360 F130	PV 360 F160
Gross weight	1 300 kg	1 600 kg	Spare wheel	●	●
Maximum payload	1 000 kg	1 220 kg	Spare wheel carrier	●	●
Unladen weight	300 kg	380 kg	Wheel block (per unit)	●	●
Axle capacity	1 300 kg	1 600 kg	Hydraulic tipping kit	●	●
Axle	1	1	Manual winch 2500 kg (+ cable 10 m)	●	●
Braked axle	●	●	Winch carrier	●	●
Tipping platform	●	●	Loading ramps kit	●	●
Gas strut assisted tipping	2	1			
Internal platform dimensions (cm)	360 x 180	360 x 190			
Overall dimensions (cm)	541 x 243	540 x 254			
Loading height (cm)	45	46			
Lights	6 function	6 function			
Wheels	165 R 13C	195/50 R 13C			

UTILITY RANGE



REV 300 F 130

- Hot dip galvanised welded chassis
- V drawbar
- Delivered with 2 gas struts as standard
- Anti-slip plywood floor 15mm
- Lashing points
- Protected 6 function light
- Tipping platform for an easy loading and unloading

TRIGANO trailers are delivered with a Certificate of Conformity (COC) and comply with the European Directive 2007/46/CE approved by the European Parliament and council

REV 300 F 130

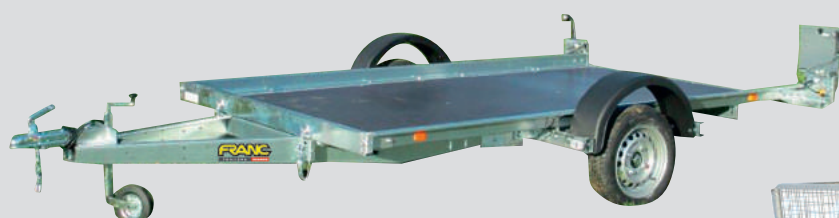

Mesh side kit + spare wheel as an extra

TRAILERS

	REV 300 F 130
Gross weight	1 300 kg
Maximum payload	1 010 kg
Unladen weight	290 kg
Axle capacity	1 300 kg
Axle	1
Braked axle	●
Tipping platform	●
Internal platform dimensions (cm)	300 x 170
Internal platform dimensions with sides (cm)	
Overall dimensions (cm)	442 x 228
Loading height (cm)	50
Lights	6 function
Wheels	165 R 13C
Jockey wheel	Ø 60

OPTIONAL ACCESSORIES

	REV 300 F 130
Spare wheel	●
Spare wheel holder	●
Hydraulic tipping kit	●
Steel high side kit - H 22 cm	●
Loading ramp - Steel, 250 cm (per unit)	
Loading ramps - Aluminium 250 cm (set)	
Rear prop stand	
Ladder rack	
Mesh high side kit - H 80 cm	
Mesh high sides - H 100 cm	●
Flat cover	
Hoop for flat cover	
High cover kit - H 140 cm	
Steel high side kit H 40 cm	
Loading ramp support	
Tailgate - H 35 cm (without sides)	●
Fixing kit for tailgate (tailgate without Steel high sides)	●
Manual winch 1800 kg (+ cable 9 m + hook)	●
Manual winch 2100 kg (+ cable 9 m + hook)	●
Winch carrier	●

NEW !

BRI 260 F150

- 1 axle 1500 kg braked
- Ladder rack supplied as an option
- 4 tilting and removable sides, removable poles
- 4 side rails H 35 cm in galvanized steel
- Reinforced structure of the top
- Hydraulic cylinder 3 expansions
- Floor / floor height 67 cm
- Double-acting manual hydraulic pump



TRAILERS	1	2	OPTIONAL ACCESSORIES
	BRI 260 F75	BRI 260 F150	
Gross weight	750 kg	1 500 kg	Spare wheel <input type="checkbox"/>
Maximum payload	750 kg	950 / 1 000 / 1 100 kg 1 200 / 1 300 / 1 400 kg	Spare wheel holder <input type="checkbox"/>
Unladen weight	436 kg	440 kg	Hydraulic tipping kit
Axle capacity	1 500 kg	1 500 kg	Steel high side kit - H 22 cm
Axle	1	1	Loading ramp - Steel, 250 cm (per unit)
Braked axle	<input type="checkbox"/>	<input type="checkbox"/>	Loading ramps - Aluminium 250 cm (set)
Internal platform dimensions (cm)	260 x 148	260 x 148	Rear prop stand
Overall dimensions (cm)	381 x 162	442 x 228	Ladder rack <input type="checkbox"/>
Loading height (cm)	102	102	Mesh high side kit - H 50 cm <input type="checkbox"/>
Wheels	165 x 13C	195/50 x 13C	Mesh high sides - H 100 cm
			Flat cover <input type="checkbox"/>
			Hoop for flat cover
			High cover kit - H 140 cm
			Steel high side kit H 40 cm
			Loading ramp support
			Tailgate - H 35 cm (without sides)
			Fixing kit for tailgate (tailgate without Steel high sides)
			Manual winch 1800 kg (+ cable 9 m + hook)
			Manual winch 2100 kg (+ cable 9 m + hook)
			Winch carrier
			Stackable mesh extensions <input type="checkbox"/>



TRIGANO trailers are delivered with a Certificate of Conformity (COC) and comply with the European Directive 2007/46/CE approved by the European Parliament and council

TRIGANO Trailer is a member of the National Trailer and Towing Association LTD



© www.reflectioncommunication.com

You may also like our wide range of accessories



Constructeur de libertés !

First french manufacturer
2 production site on 40 000 m²
800 trailers built per day

